

### Front Suspension

#### Steering System:

Swing Rack  Bellcrank Rack

#### Anti Roll Bar:

2.2mm Green   
 2.3mm White   
 2.4mm Blue   
 2.5mm Yellow

Bumpsteer Washers: \_\_\_\_\_

Camber: \_\_\_\_\_

Caster: \_\_\_\_\_

Toe: \_\_\_\_\_

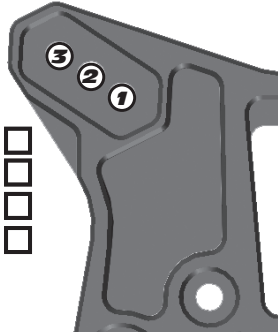

**Upper Hinge Pin Bushing**

Front # \_\_\_\_\_  
 Up  Down

Rear # \_\_\_\_\_  
 Up  Down

**B-Plate Type**

Low  Original

**Kickup Bushing A-Plate**

# \_\_\_\_\_  
 Up  Down

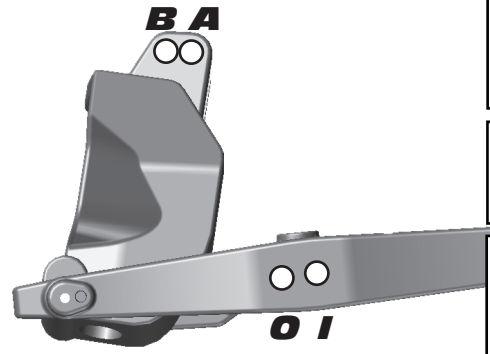

Ride Height: \_\_\_\_\_

### Rear Suspension

#### Wheelbase:

Long   
 Medium   
 Short

#### Anti Roll Bar:

2.5mm Green   
 2.6mm White   
 2.7mm Blue   
 2.8mm Yellow

Camber: \_\_\_\_\_



**Toe Bushing D-Plate**

# \_\_\_\_\_  
 In  Out



Ride Height: \_\_\_\_\_

**Squat Bushing C-Plate**

# \_\_\_\_\_  
 Up  Down

### Front Shocks

Spring: \_\_\_\_\_ Shock Cap: \_\_\_\_\_  
 Shock Fluid: \_\_\_\_\_ Length: \_\_\_\_\_  
 Piston: \_\_\_\_\_ Rebound: \_\_\_\_\_

### Rear Shocks

Spring: \_\_\_\_\_ Shock Cap: \_\_\_\_\_  
 Shock Fluid: \_\_\_\_\_ Length: \_\_\_\_\_  
 Piston: \_\_\_\_\_ Rebound: \_\_\_\_\_

### Chassis Braces / Wheel Hex

Chassis Braces: Wheel Hex:  
 Pivot  Standard   
 Molded  Narrow   
 Aluminum

### Chassis Weight

Weight: \_\_\_\_\_  
 \_\_\_\_\_  
 \_\_\_\_\_

### Rear Hubs

Rear Hubs: Standard   
 CNC FT Alum.

### Differentials

Front Diff Fluid: \_\_\_\_\_  
 Center Diff Fluid: \_\_\_\_\_  
 Rear Diff Fluid: \_\_\_\_\_

### Body / Wing

Body Type: \_\_\_\_\_  
 Wing Type: \_\_\_\_\_  
 Gap to Tower (MM): \_\_\_\_\_

### Gearing / Clutch

Spur Gear: \_\_\_\_\_  
 Clutch Bell: \_\_\_\_\_  
 Clutch Shoes: \_\_\_\_\_  
 Clutch Spring: \_\_\_\_\_

### Engine

Engine: \_\_\_\_\_  
 Restrictor: \_\_\_\_\_ Temp: \_\_\_\_\_  
 Muffler: \_\_\_\_\_  
 Glow Plug: \_\_\_\_\_ Fuel: \_\_\_\_\_

### Tires

Tire (F/R): \_\_\_\_\_ / \_\_\_\_\_  
 Compound (F/R): \_\_\_\_\_ / \_\_\_\_\_  
 Inserts (F/R): \_\_\_\_\_ / \_\_\_\_\_  
 Wheel (F/R): \_\_\_\_\_ / \_\_\_\_\_  
 Notes: \_\_\_\_\_

### Radio / Servos

Radio: \_\_\_\_\_ Brake Bias: \_\_\_\_\_  
 Throttle / Steering Servo: \_\_\_\_\_ / \_\_\_\_\_  
 Throttle / Brake expo: \_\_\_\_\_ / \_\_\_\_\_  
 Steering expo: \_\_\_\_\_  
 Dual Rate: \_\_\_\_\_

### Race and Vehicle Comments

Qualify: \_\_\_\_\_ Main: \_\_\_\_\_ Finish: \_\_\_\_\_ TQ: \_\_\_\_\_  
 Comments: \_\_\_\_\_  
 \_\_\_\_\_  
 \_\_\_\_\_

### Track Info

Traction: High  Medium  Low   
 Surface: Smooth  Bumpy  Blue Groove   
 Soft Dirt  Grass  Clay  Wet   
 Astroturf  Dusty  Other: \_\_\_\_\_